

- | | |
|---|--|
| <ul style="list-style-type: none"> ■ Bending beam load cell ■ Fully stainless steel ■ 3000 divisions O.I.M.L. R60 class C * ■ Hermetically sealed, fully welded ■ Protected IP 68 (EN 60529) ■ Available in ATEX  version (optional) Zone 0-1-2 (gas) and 20-21-22 (dust) | <ul style="list-style-type: none"> ■ Biegestabwägezelle ■ Komplet in Edelstahl ■ 3000 Teile O.I.M.L. R60 Klasse C * ■ hermetisch dicht verschweißt ■ Schutzart IP 68 (EN 60529) ■ Erhältlich in ATEX  -Ausführung (optional) Zone 0-1-2 (Gas) und 20-21-22 (Staub) |
|---|--|

Model Modell	Nominal capacity Nennlast Ln	Accuracy class Genauigkeitsklasse *n. OIML	Minimum division Kleinster Teilungswert vmin	Service load Gebrauchslast 150 % Ln	Safe load Grenzlant 200 % Ln
340 15 kg	15 kg	3000	1.5 g	22 kg	30 kg
340 30 kg	30 kg	3000	3 g	45 kg	60 kg
340 50 kg	50 kg	3000	5 g	75 kg	100 kg
340 75 kg	75 kg	3000	7.5 g	112 kg	150 kg
340 100 kg	100 kg	3000	10 g	150 kg	200 kg
340 150 kg	150 kg	3000	15 g	225 kg	300 kg
340 200 kg	200 kg	3000	20 g	300 kg	400 kg
340 250 kg	250 kg	3000	25 g	375 kg	500 kg
340 300 kg	300 kg	3000	30 g	450 kg	600 kg
340 500 kg	500 kg	3000	50 g	750 kg	1000 kg
340 750 kg	750 kg	3000	75 g	1125 kg	1500 kg
340 1000 kg	1000 kg	3000	100 g	1500 kg	2000 kg
340 1500 kg	1500 kg	2000	150 g	2250 kg	2500 kg

MODEL 340

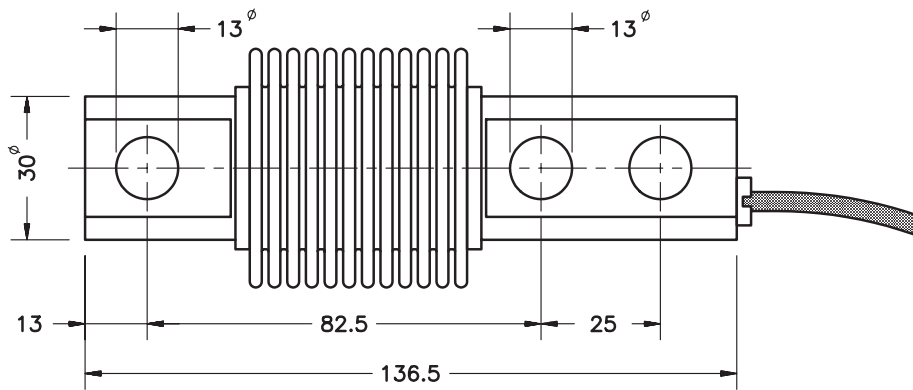
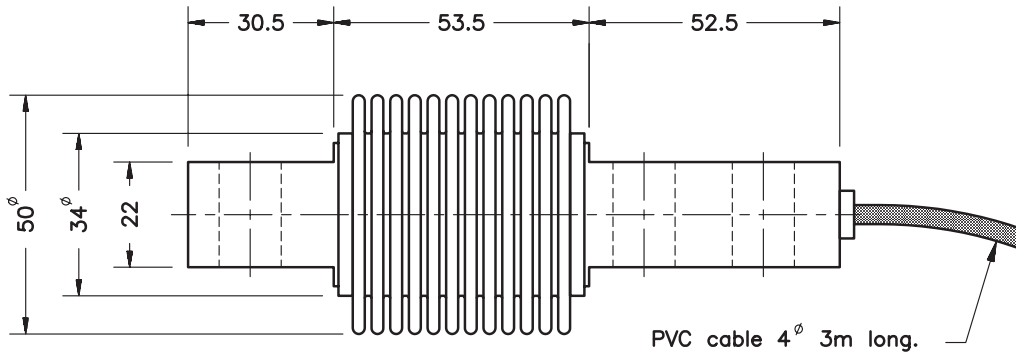

Dimensions in mm. Abmessungen in mm.

Transport weight - Transportgewicht: 0.5 kg

SPECIFICATIONS			TECHNISCHE DATEN
Nominal capacities (Ln)	15-30-50-75-100 150-200-250-300 500-750-1000-1500	kg	Nennlasten (Ln)
Accuracy class	3000	n. OIML (3)	Genauigkeitsklasse
Minimum dead load	0	%Ln	Minimale Vorlast
Service load	150	%Ln	Gebrauchslast
Safe load limit	200	%Ln	Grenzlast
Total error	< ± 0.017	%Sn (1) (3)	Zusammengesetzter Fehler
Repeatability error	< ± 0.015	%Sn	Wiederholgenauigkeit
Temperature effect: on zero	< ± 0.01	%Sn/5°K	Temperaturfehler: Nullpunkt
on sensitivity	< ± 0.006	%Sn/5°K	Kennwert
Creep error (30 minutes)	< ± 0.016	%Sn	Kriechfehler (30 min)
Temperature compensation	-10...+40	°C	Nenntemperaturbereich
Temperature limits	-20...+50	°C	Arbeitstemperaturbereich
Nominal sensitivity (Sn)	2 $\pm 0.1\%$	mV/V (2)	Nennkennwert (Sn)
Nominal input voltage	10	V	Nom. Speisespannung
Maximum input voltage	15	V	Max. Speisespannung
Input impedance	400 ± 20	Ω	Eingangswiderstand
Output impedance	350 ± 3	Ω	Ausgangswiderstand
No load output	< ± 2	%Sn	Nullsignaltoleranz
Insulation resistance	> 5000	M Ω	Isolationswiderstand
Maximum deflection (at Ln)	0.2-0.4	mm	Nennmessweg (bei Ln)

ELECTRICAL CONNECTION ELEKTRISCHER ANSCHLUSS:

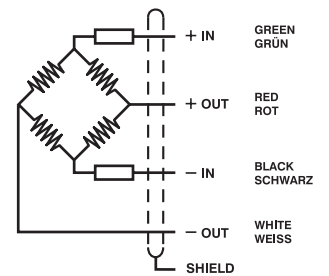

- (1) Total error: Non Linearity and Hysteresis / Zusammengesetzter Fehler: Nichtlinearität und Hysterese
 (2) Ln ≤ 20 kg, 2 $\pm 0.2\%$
 (3) 1500 kg: 2000 n. OIML

ACCESSORIES FOR MODEL 340
ZUBEHÖR FÜR MODELL 340

Acc. **30904**: Silent-block bearing up to 50 kg
(blue rubber) / Elastomerlager
(blau), bis 50 kg

Acc. **30905**: Silent-block bearing up to 300 kg /
Elastomerlager, bis 300 kg

Stainless steel / Edelstahl

50/300 kg max.

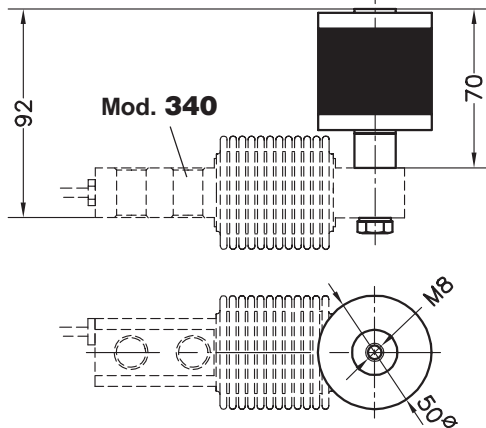

Transport weight - *Transportgewicht*: 0.5 kg



Acc. **34903**: Base plate: Steel zinc-plated
Grundplatte: Verzinkter Stahl-
Elastomer

Acc. **34903i**: Base plate: Stainless steel
Grundplatte: Edelstahl und
Elastomer

Acc. **34906**: Silent-block bearing up to 750 kg /
Elastomerlager, bis 750 kg

Stainless steel / Edelstahl

750 kg max.

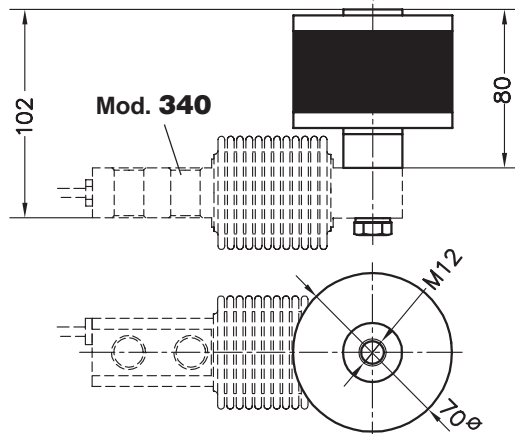

Transport weight - *Transportgewicht*: 0.5 kg

Dimensions in mm. *Abmessungen in mm.*

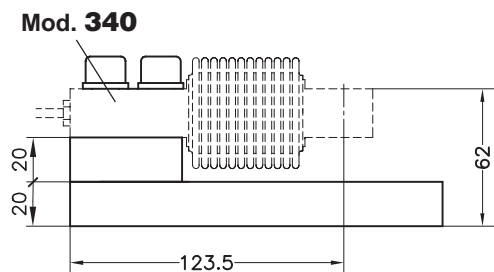
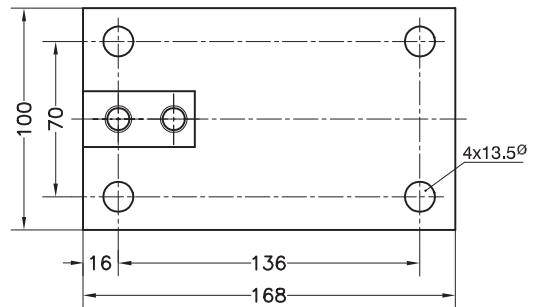

Transport weight - *Transportgewicht*: 3 kg

TENSION ACCESSORIES FOR MODEL 340
ZUGKRAFTZUBEHÖR FÜR MODELL 340

Acc. 34905

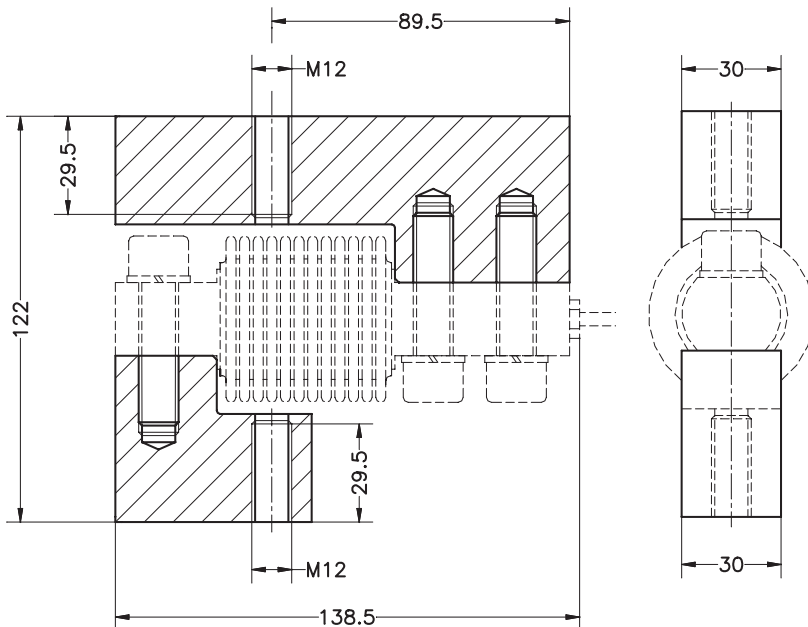

- Material: steel alloy zinc-plated
- Material: Stahl, verzinkt

Dimensions in mm. Abmessungen in mm.

Transport weight - Transportgewicht: 1.9 kg

Acc. 31903

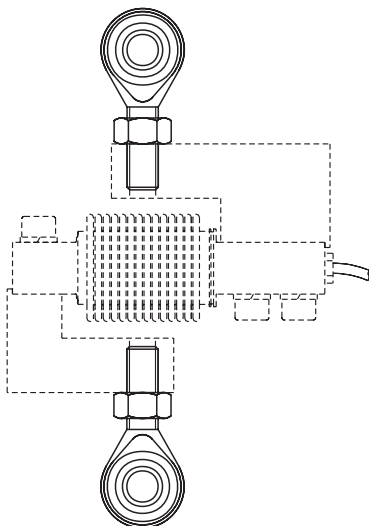

Steel alloy zinc-plated
Stahl, verzinkt

Transport weight - Transportgewicht: 0.4 kg

Mod. 340 + Acc. 31903 + Acc. 34905

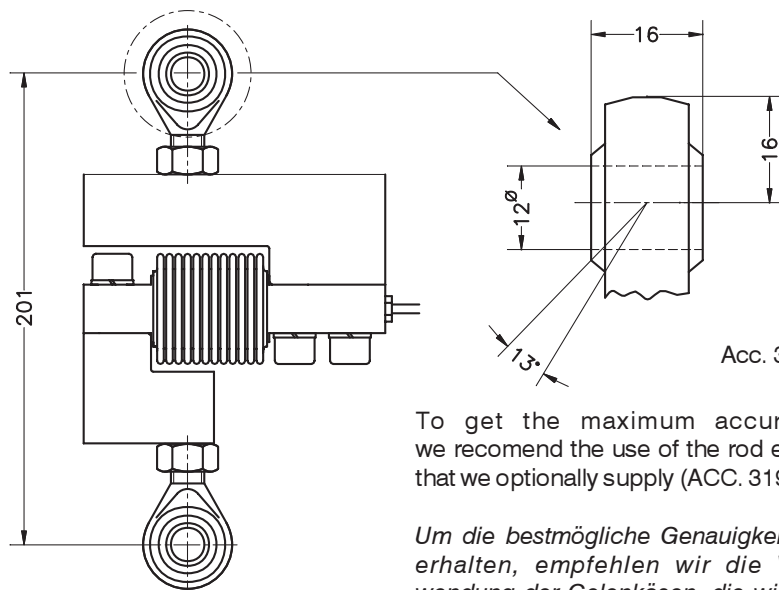

Acc. 31903

To get the maximum accuracy we recommend the use of the rod ends that we optionally supply (ACC. 31903)

Um die bestmögliche Genauigkeit zu erhalten, empfehlen wir die Verwendung der Gelenkösen, die wir als Zubehör anbieten (ACC.31903)

LOAD FOOT ACCESSORY FOR MODELS 340-350
SELBSTZENTRIERENDER LASTFUSS FÜR MOD. 340-350

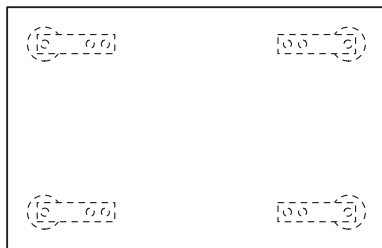
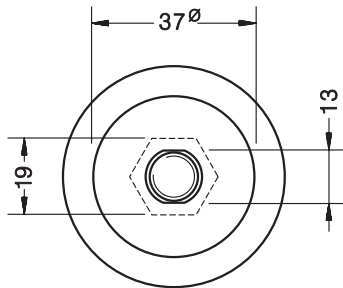
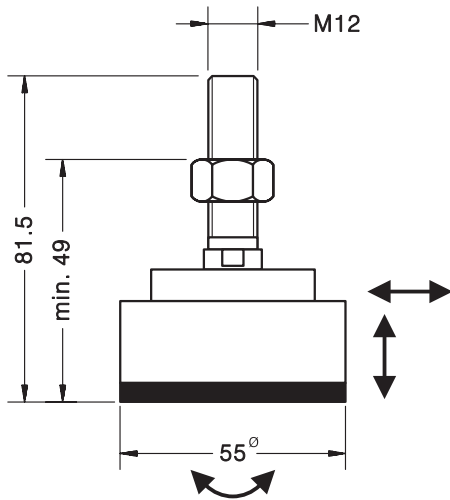

- **Materials: stainless steel and rubber**
- **Material: Edelstahl und Elastomer**

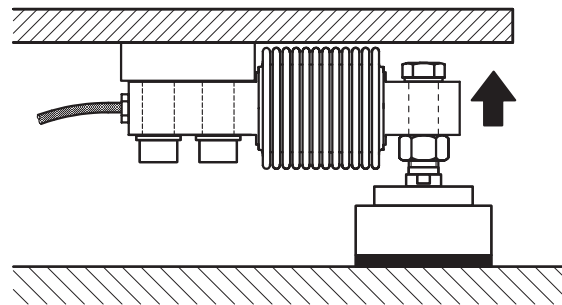

Dimensions in mm. Abmessungen in mm.

Transport weight - Transportgewicht: 0.33 kg

**LOAD FOOT ACCESSORY FOR MODELS 340-350
SELBSTZENTRIERENDER LASTFUSS FÜR MOD. 340-350**

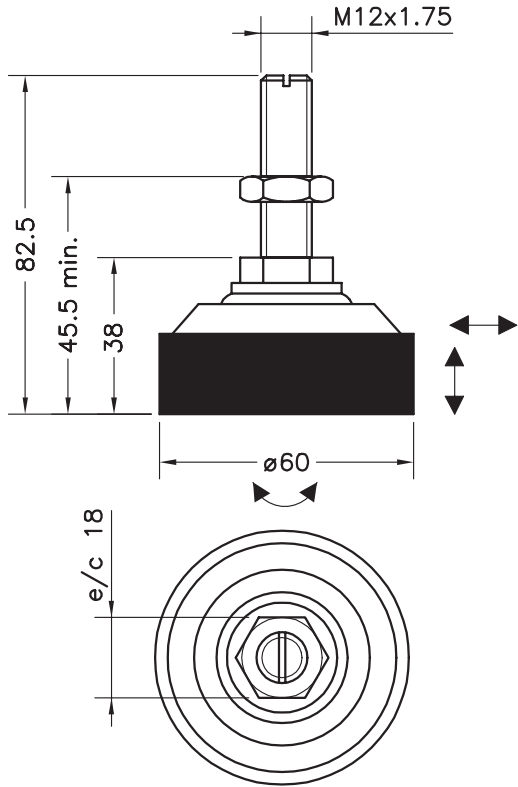

- **Materials: stainless steel and rubber**
- **Material: Edelstahl und Elastomer**

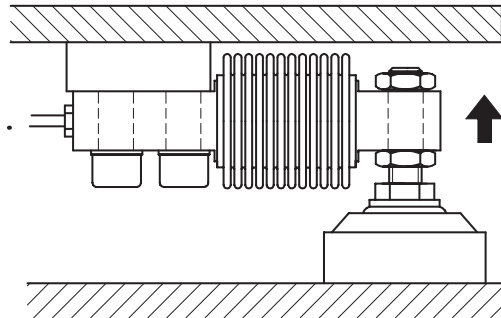
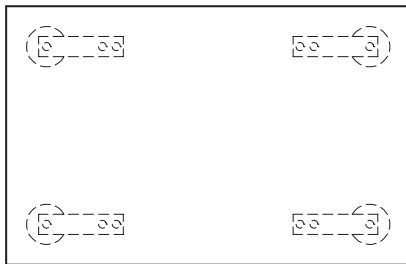
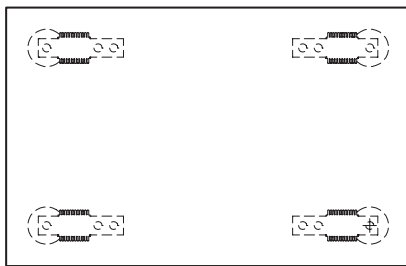

Mod. 340
+
Acc. FT12i

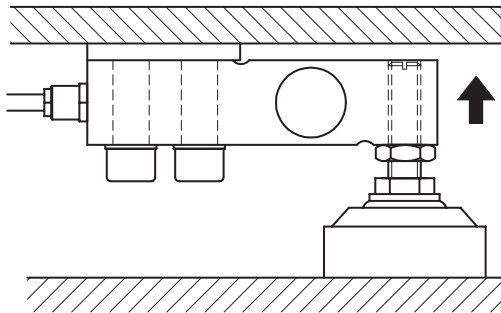

Mod. 350
(300...2000 kg)
+
Acc. FT12i

Dimensions in mm. Abmessungen in mm.

Transport weight - Transportgewicht: 0.42 kg