

- Double bending beam load cell
- Measuring element from Steel alloy
- 3000 divisions O.I.M.L. R60 class C
- Protected IP 66 (EN 60529)
- Single point load cell. High accuracy with off-center loads
- Protected against corrosion by nickel-plated treatment
- Applications:
 - Direct platform up to 500 x 500 mm
 - Filling scales

- Doppelbiegebalkenprinzip
- Messkörper aus Stahl
- 3000 Teile O.I.M.L. R60 Klasse C
- Schutzart IP 66 (EN 60529)
- Hohe Genauigkeit bei exzentrischer Lasteinleitung
- Korrosionsschutz durch Vernickelung
- Anwendungen:
 - Plattformwaagen mit nur 1 Wägezelle, 500 x 500 mm
 - Behälterwaagen

Model Modell	Nominal capacity Nennlast Ln	Accuracy class Genauigkeitsklasse n. OIML	Minimum division Kleinster Teilungswert vmin	Service load Gebrauchslast 150 % Ln	Platform Plattform A x B mm	Accuracy Genauigkeit 1/3 Ln
160 15 kg	15 kg	3000	1.5 g	22.5 kg	500 x 500	3000 v
160 20 kg	20 kg	3000	2 g	30 kg	500 x 500	3000 v
160 30 kg	30 kg	3000	3 g	45 kg	500 x 500	3000 v
160 50 kg	50 kg	3000	5 g	75 kg	500 x 500	3000 v
160 75 kg	75 kg	3000	7.5 g	112.5 kg	500 x 500	3000 v
160 100 kg	100 kg	3000	10 g	150 kg	500 x 500	3000 v
160 150 kg	150 kg	3000	15 g	225 kg	500 x 500	3000 v

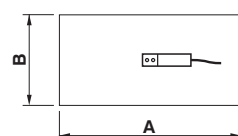

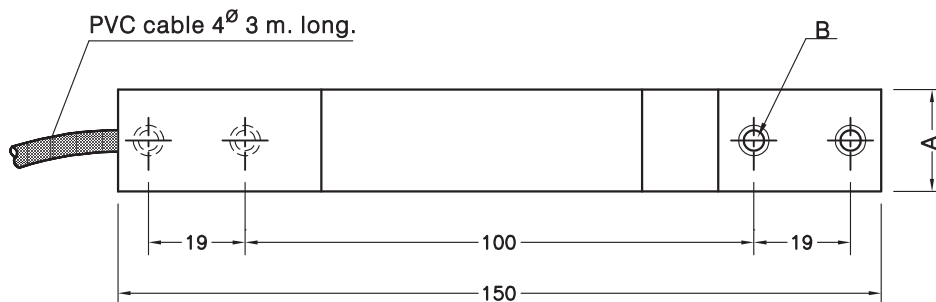
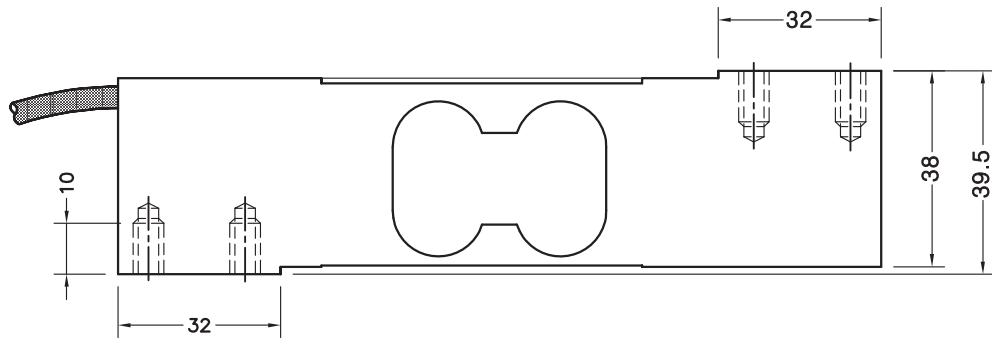

Nominal load (kg) Nennlast (kg)	Transport weight Transportgewicht	A	B
15-20-30	0.7 kg	20	M6
50-75-100-150	0.85 kg	25	M8

Dimensions in mm. *Abmessungen in mm.*

SPECIFICATIONS			TECHNISCHE DATEN
Nominal capacities (Ln)	15-20-30-50 75-100-150	kg	Nennlasten (Ln)
Accuracy class	3000	n. OIML	Genauigkeitsklasse
Minimum dead load	0	%Ln	Minimale Vorlast
Service load	150	%Ln (1)	Gebrauchslast
Safe load limit	200	%Ln (1)	Grenzlast
Total error	< ±0.017	%Sn (2)	Zusammengesetzter Fehler
Repeatability error	< ±0.01	%Sn	Wiederholgenauigkeit
Temperature effect: on zero	< ±0.01	%Sn/5°K	Temperaturfehler: Nullpunkt
on sensitivity	< ±0.006	%Sn/5°K	Kennwert
Creep error (30 minutes)	< ±0.016	%Sn	Kriechfehler (30 min)
Temperature compensation	-10...+40	°C	Nenntemperaturbereich
Temperature limits	-20...+70	°C	Arbeitstemperaturbereich
Nominal sensitivity (Sn)	2 ±10%	mV/V (3)	Nennkennwert (Sn)
Nominal input voltage	10	V	Nom. Speisespannung
Maximum input voltage	15	V	Max. Speisespannung
Input impedance	400 ±20	Ω	Eingangswiderstand
Output impedance	350 ±3	Ω	Ausgangswiderstand
No load output	< ±2	%Sn	Nullsignaltoleranz
Insulation resistance	> 5000	MΩ	Isolationswiderstand
Maximum deflection (at Ln)	0.3-0.5	mm	Nennmessweg (bei Ln)

ELECTRICAL CONNECTION
ELEKTRISCHER ANSCHLUSS:

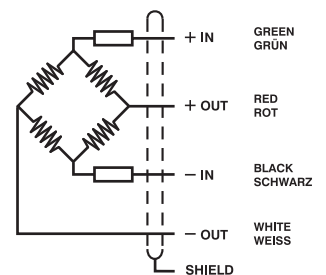

- (1) Only central loads on the load cell. Not for off-center loads
Nur bei zentrischer Belastung. Nicht bei exzentrischer Last
- (2) Total error: Non Linearity and Hysteresis / Zusammengesetzter Fehler: Nichtlinearität und Hysterese
- (3) 2 ±0.1% mV/V optional